



Classic TBi 380

Aircooled

Uses same gasnozzles as TBi 260 / 411 / 511

TBi-Flex rubber coaxial cable

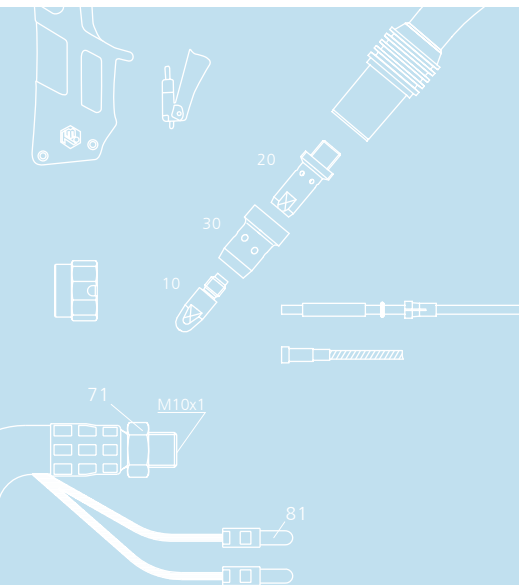

Technical data

MIG / MAG (GMAW) Semi-automatic welding torch TBi 380

Rating at 60% ED
(10 min. cycle)

- Mixed gas: 360 A
- CO₂: 380 A

Cooling method Aircooling

Wire diameter 1.2 - 1.6 mm

Gas flow 14 l/min

Technical specification according to IEC 60974-7

Weight with 1.5m cabel 1.80 kg

Connection Euro-Central connector
Other connectors (e.g. Cloos®, ESAB®) available upon request.

Ordering Information

TBi 380 ESG, 50° bent 917P3413_0*

* At the blank, please insert 3, 4 or 5 for a torch length of 3, 4 or 5 m.

Torch rating will be reduced when using pulsed-arc power sources.
Special torch necks and custom lengths of the coaxial cable are available upon request.

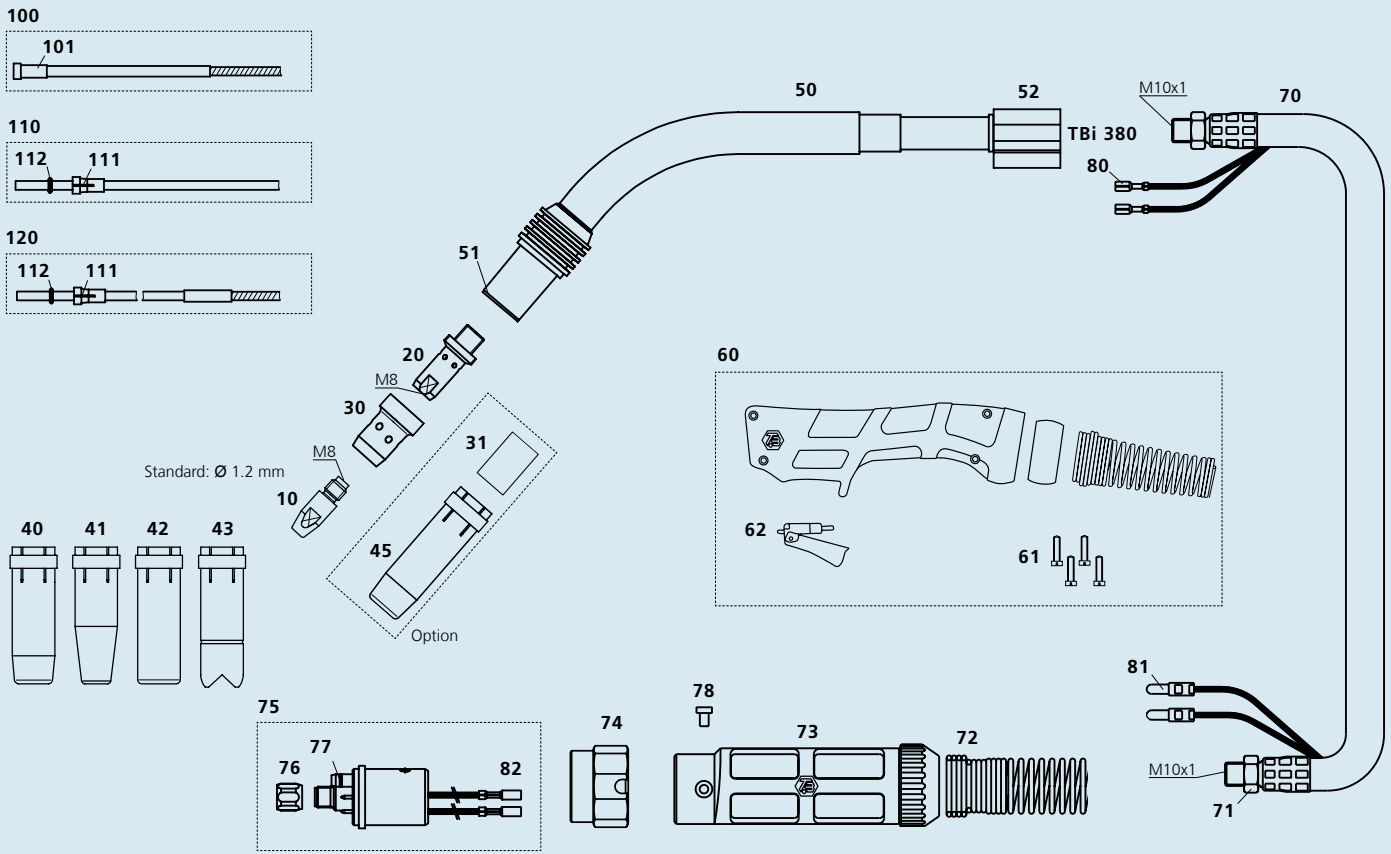

Pos.	Description	Part. No.
Contact tips		
▶ 10	Contact tip M8x30, Ecu	340P_1262*
10	Contact tip M8x30, CuCrZr	340P_3262*
10	Contact tip M8x30 Alu, Ecu	341P_1262*
Tip holders		
▶ 20	Tip holder M8 / L=36 mm	342P054884
Gas diffusers / Nozzle insulators		
▶ 30	Gas diffuser, white	130P002017
30	Gas diffuser, ceramic	130P002019
30	Gas diffuser, black	130P002026
30	Gas diffuser, brown	130P002031
31	Nozzle insulator, only for pos. 45	346P054860
Gas nozzles		
▶ 40	Nozzle con. diam. 16.0 mm	345P012030
41	Nozzle con. diam. 14.0 mm	345P013030
42	Nozzle cyl. diam. 20.0 mm	345P011030
43	Spot weld nozzle diam. 20.0 mm	345P015030
45	Nozzle con. diam. 16.0 mm HD	345P012032

Pos.	Description	Part. No.
Spare parts		
50	Torch neck TBI 380, 50°	917P001001
51	Insulating washer	130P002004
52	PVC body	600P002018
60	Handle blue, aircooled, cpl. kit	380P220400
61	Cross recessed screw M 3.5x14	100P008413
62	Trigger, red, 2 poles	385P021016
70	TBI-Flex coaxial cable 50 sqmm	360P5011_0*
71	Hex nut M10x1	101P002005
72	Spring support small 16-50 sqmm	600P102099
73	Cable support cpl. (2 pieces)	701P001045

Pos.	Description	Part. No.
74	Adaptor nut	701P001013
75	Central adaptor ESG cpl., 2 poles, moveable pins	701P001048
76	Sleeve nut M10x1	701P002005
77	O-ring 4.0x1.0 mm (gas nipple)	365P100040
78	Slotted screw M4x6	100P008401
80	Cable lug, flat	375P000023
81	Insulated connector, male, round	375P000004
82	Insulated connector, female, round	375P000003
Wire guides		
▶ 100	Liner w/ insulation yellow (x.40 m) for wire 1.2-1.6	324P2545_4*
101	Collet for liners dia. 4.5 mm	330P025045
110	Teflon liner yellow (x.50 m) for wire 1.2-1.6	326P2747_5*
111	Collet for teflon and PA liner 2.7x4.7 mm	331P027047
112	O-ring 3.50x1.50 mm (teflon liner)	365P150035
120	PA-Alu wire guide (x.50 m) for wire 1.2-1.6	328P2347_A*
120	PA-Alu wire guide (x.50 m) for wire 2.0-2.4	328P2947_A*

▶ = Standard parts

* At the blank, please insert suitable information for torch length or wire diameter, e.g. 08 for 0.8 mm or 3 for 3 m.

© 2006 TBI Industries GmbH. All rights reserved. Subject to change without notice. Warranty only when using original TBI consumables and spare parts. Excerpts and reprints not permitted. Nr. DOKP111172, 03/2006.

TBI Industries GmbH
 Ruhberg 14
 D-35463 Fernwald-Steinbach
 P.O. Box 67
 D-35461 Fernwald-Steinbach

Tel. + 49 6404 9171-0
 Fax. + 49 6404 9171-40
 Internet: www.tbi-industries.com
 E-mail: info@tbi-industries.com